

Fuel Level Monitoring (FLM) (System Description)

A Product of
Microsystems (Pvt) Ltd.

Key Features

- Highly reliable
- Easy to install
- Real time monitoring
- Auto generated alerts
- Backup battery
- Error reporting
- Generator On/Off alerts

The Fuel Level Monitoring (FLM) unit consists of the following subsystems which are installed near the Fuel Tank; the unit is mounted on wall.

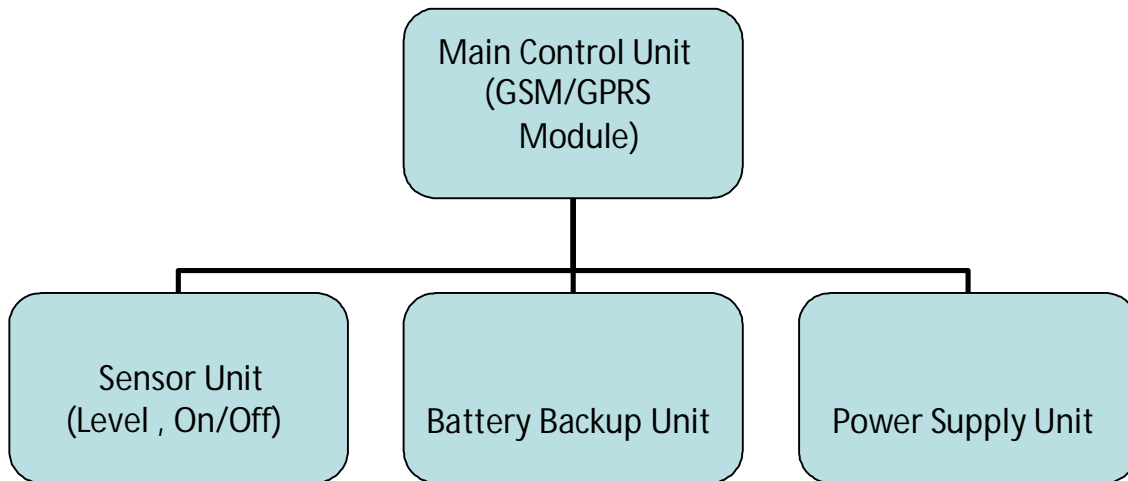

Main Control Unit (MCU)

This unit works on DC 12v input, it has GSM/GPRS modem installed for communication. The GSM (Specifications below) communicates with the MCU messages over the GPRS network using internet. The MCU updates a dedicated website set up for this purpose. This site can only be accessed by an authorized person so as to monitor the network. The MCU has an LCD display unit that displays the fuel level locally. It not only monitors the Fuel tank but also update the site in real time thus making an ideal solution for level monitoring.

Generator ON/Off Sensor

This unit is installed on the Generator it keeps monitoring the output voltage of generator and continuously sends information to MCU which proceeds further.

Level Sensor

The level Sensor (completely sealed explosion proof sensor) is immersed in the fuel tank that signals the MCU about the Fuel level.



Mezzanine Floor, 9-C Sunset Lane – 5,
Phase II Ext. D.H.A. Karachi – 75500
Tel : 0213-5881580
Fax : 0213-5389432
Email: sales@mslpk.com
info@mslpk.com
Web : www.mslpk.com

The Battery Backup

The Backup Battery provides a backup time of 12 hours. It has a built-in 12 volts 7 ampere sealed battery and the charging unit. There is also a provision of sending the status of the battery to the MCU in case there is a fault in the unit thus providing more secure solution.

Website

A website is made to monitor the Fuel levels; only an authorized person can login to the website and can view the Fuel levels this allows easy access from anywhere, just the administrator or any authorized person needs to connect to the internet. It would be possible to view the Fuel Levels in Graphical as well as Tabular form. It would also be possible to show actual liters if the tanks are of equal dimensions.